

CR55

Bar code reader

en 02-2016/07 50129160-01



50 ... 230mm



- CCD linear scanner for all common 1D bar codes
- Very compact design
- Integrated decoder
- RS 232 or USB 2.0 interface
- Metal case
- Simple mounting and fastening

Dimensioned drawing

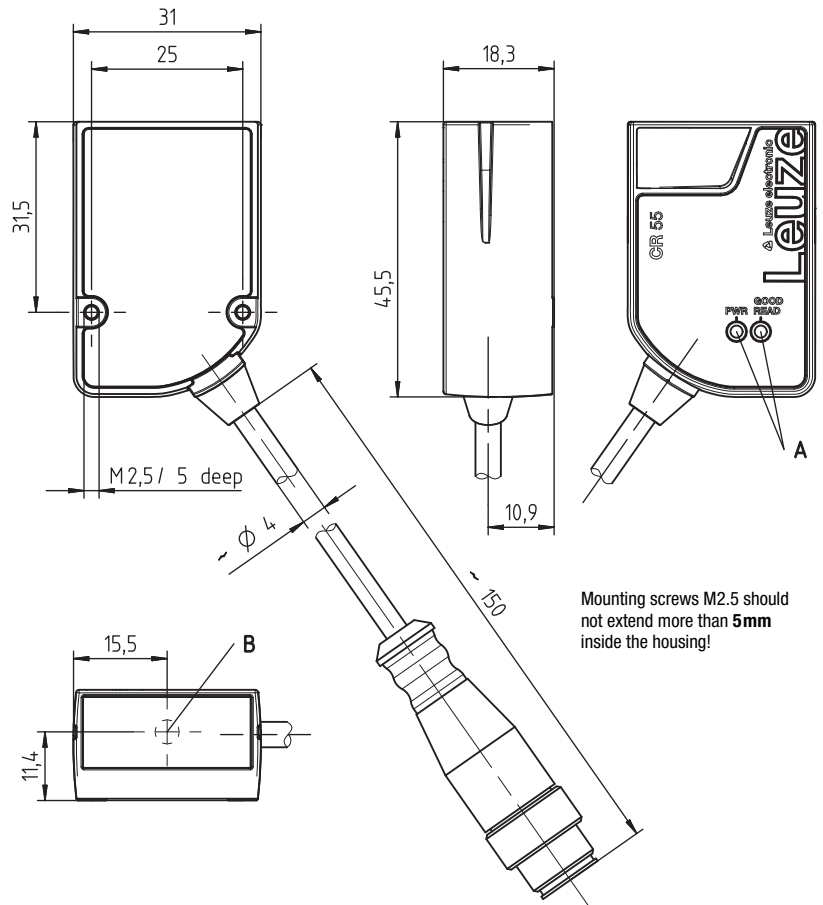

Mounting screws M2.5 should not extend more than 5mm inside the housing!

- A Status LEDs
- B Receiving optics and LED scanning line

Electrical connection

RS232 - cable

Wire color	Signal	Description	IN / OUT
Red	+5VDC	Power supply 5VDC	IN
Violet	GND	Power supply 0VDC / Ground	IN
Black	SW OUT	Switching output	OUT
Orange	SW IN	Switching input	IN
White	RS 232 RxD	Serial interface	IN
Green	RS 232 TxD	Serial interface	OUT

RS232 - M12 connector

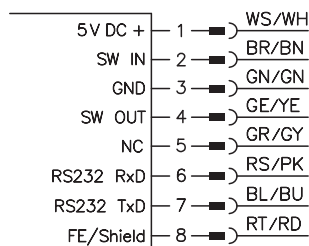

USB

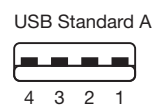

PIN	Signal
1	+ 5 V DC
2	Data-
3	Data+
4	GND

Accessories:

(available separately)

- Connection cable M12, socket straight, 8-pole, cable length 2m, shielded K-D M12A-8P-2m-PUR (part no. 50104591)

We reserve the right to make changes • DS\_CR55\_en\_50129160\_01.fm



## Specifications

### Optical data

Optical System	CCD Linear Imager <sup>1)</sup>
Light source	integrated LED (visible red light)
Wavelength	617 nm
Scanning rate	typ. 330 Scans/s
Read distance	50 mm ... 230 mm
Contrast	30 % modulation

### Code specifications

Code types	2/5 Interleaved, Code 39, Code 128 (incl. Typ C), EAN 128, EAN 8, EAN 13, UPC A, UPC E, Codabar, Code 93
Modulbreite	5 ... 20 mil / 127 ... 500 μm (depending on read distance)

### Electrical data

Operating voltage	4,5 ... 5,5 VDC (PELV)
Current consumption	max. 120 mA
LEDs	1 device status (PWR), 1 read status (GOOD READ)

### Interface

Interface type	RS 232 or USB 2.0 (virtual COM, HID)
Baud rate RS232	300 ... 115.200 Bd, configurable
Data formats RS232	configurable
Trigger	switching input (RS232 only, active/inactive = 0V/+5V or un-wired) or Presentation Mode
Switching output	RS232: NPN transistor output, max. 20 mA (Good Read)

### Mechanical data

Housing	metal, diecast aluminium
Weight	45 g (without cable)
Dimensions (H x W x D)	18.3x31x45.5 mm
Mounting	2 threaded holes M2.5, 5 mm deep
Connection type	RS232: fixed cable, 2 m long, 6 x 0.081 mm <sup>2</sup> (6 x 28 AWG) or approx. 0.15 m cable with M12 connector, 8-pole, A-coded USB: fixed cable, 1.8 m long, with USB connector standard A

### Environmental data

Ambient temperature (operation)	0°C ... +50°C
Ambient temperature (storage)	-20°C ... +60°C
Air humidity	max. 90% rel. humidity, non-condensing
Protection class	IP 54
Electromagnetic compatibility	EN 55022, IEC 62471
Conformity	CE, FCC
Certifications	UL 60950-1, CSA C22.2 No. 60950-1-07

1) The imager module contains diboron trioxide (declaration according to REACH regulation)

## Remarks

### Operate in accordance with intended use!

- ⚠ This product is not a safety sensor and is not intended as personnel protection.
- ⚠ The product may only be put into operation by competent persons.
- ⚠ Only use the product in accordance with the intended use.

### ● Features

Compact scanner with integrated decoder for all common 1D bar codes. Data transmission via configurable RS232 or USB 2.0 interface.

### ● Driver

USB driver for configuration of the CR55 scanners:

**Download**  
"LeAnalysisCollectionSetup" from [www.leuze.com](http://www.leuze.com)

## Reading field

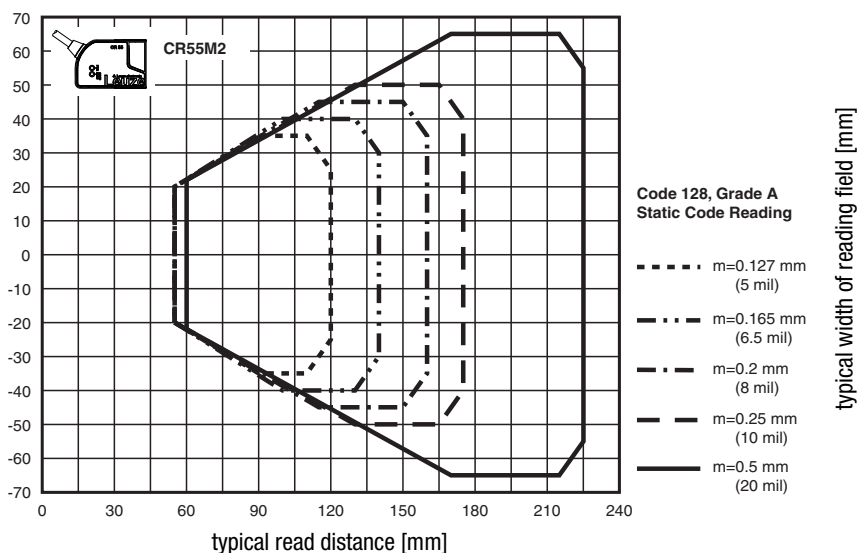

## Order guide

### CCD Linear Imager with

	Designation	Part No.
RS 232 interface, fixed cable, 2 m long	CR55M2/R2	50126080
RS 232 interface, 0.15 m cable with M12 connector	CR55M2/R2-150-M12.8	50131582
USB interface, fixed cable, 1.8 m long	CR55M2/UB-1800-S6	50127723